

OUR PRODUCTS

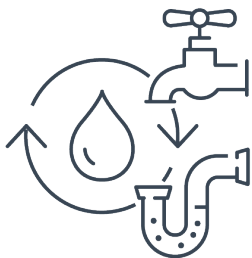
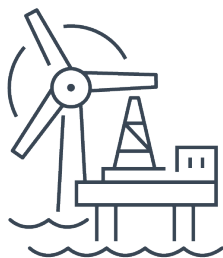
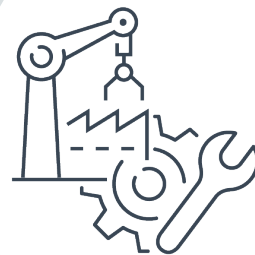

**STROBL
PUMPEN**

Strobl Pumpen – Your partner for reliable centrifugal pumps “Made in Germany”

Since 2006, **Strobl Pumpen** has been representing the highest quality, innovation, and precision in fluid handling. Whether for municipal applications, mechanical engineering, shipbuilding, or the demanding chemical and oil industries – we offer **customized pump solutions** that perfectly fit your requirements.

Our goal is simple: to find **the best solution for your pumping challenge**. That’s why we not only supply individual pumps, but also complete systems and packages – all from one single source.

Quality you can rely on:

Our products are designed and manufactured exclusively in Germany and proudly bear the “Made in Germany” seal of quality. From the initial design to final testing, precision is our top priority.

Our ISO 9001 certification guarantees consistently high standards – day after day, year after year.



WATER AND WASTEWATER



BUILDING TECHNOLOGY



CLEANING, WASHING & ENVIRONMENT



FOOD & DRUGS



INDUSTRY & PLANT ENGINEERING



CHEMICAL & PETROCHEMICAL INDUSTRY



OFFSHORE



SHIPS & TRUCKS



CUSTOMIZED SOLUTIONS



„Our highly motivated team is the heart of our success – dedicated, solution-oriented, and always focused on what matters most: **Your satisfaction.**“

Christoph Strobl (CEO) and Robert Strobl (Founder and CEO)



A family business with heart and mind:

As a family-owned and managed company based in Hilpoltstein, Bavaria, near Nuremberg, we combine strong traditional values with modern engineering expertise.

Strobl Pumpen – We move liquids. Precisely. Reliably. Sustainably.



Innovation meets responsibility:

We think ahead – also with the future in mind. Sustainability is not just a buzzword for us, but a lived reality.

- ⦿ energy-efficient machinery
- ⦿ rainwater harvesting
- ⦿ electric vehicle fleet
- ⦿ energy-optimized new buildings



are all part of our corporate philosophy. Since 2019, we have been a proud member of a Bavarian environmental alliance called “**Umweltpakt Bayern**” and voluntarily commit to additional environmental measures.



WATER AND WASTEWATER

The **Sewage Water Pumps (AWP)** are ideal for conveying solid loaded liquids, crude wastewaters, or liquids with hard particles, due to their wide free passages. The pumps can be used in all areas of water and wastewater applications by their multiple set up possibilities (dry, flooded or submerged).

- ⦿ Free passages of 20-150 mm depending on impeller and execution
- ⦿ Multi-blade channel type impellers and free flow impellers
- ⦿ Versatile choice of materials and seals
- ⦿ Non-clog or with cutting plate or cutting device





Our **Drainage Pumps (KEP)** are suitable for drainage applications with intermittent duty, such as sumps or pits. The vertical Drainage Pumps are variable in length and can be equipped with flanges in 1 ½", 2" and 2 ½".

- ⦿ Insensitivity against sand and small stones
- ⦿ Different mounting lengths (max. 2.65 m)
- ⦿ Dry motor set up



You can find the detailed catalog directly at www.strobl-pumpen.de in the "Downloads" section

The **Compact Pumps in inline version (EBPI)** are ideal for conveying liquids in the building technology. They can be directly mounted into the piping and are designed with a back-pull-out system that makes maintenance easier. The pumps were constructed in accordance with the ErP-guideline and are supplied with impellers from casted stainless steel as standard.



- ⦿ Vibration and temperature resistance
- ⦿ Versatile choice of materials and seals
- ⦿ Connections for pressure and temperature sensors

You can find the detailed catalog directly at www.strobl-pumpen.de in the "Downloads" section



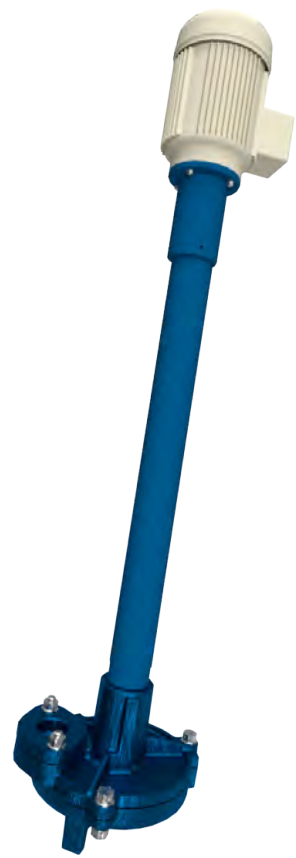

The **Sewage Water Pumps (AWP)** can be used in all sectors of building industry with their different possibilities of set up (dry, flooded or submerged). Conveying clean, polluted liquid with or without hard particles is smoothly possible.

The **Drainage Pumps (KEP)** can also be used in the construction industry. The possibility of intermittent operation and the insensitivity of the pump against sand and small stones are the base for their main application, the drainage of sumps.

Further Information can be found in the sector "Water and Wastewater".

CLEANING, WASHING & ENVIRONMENT

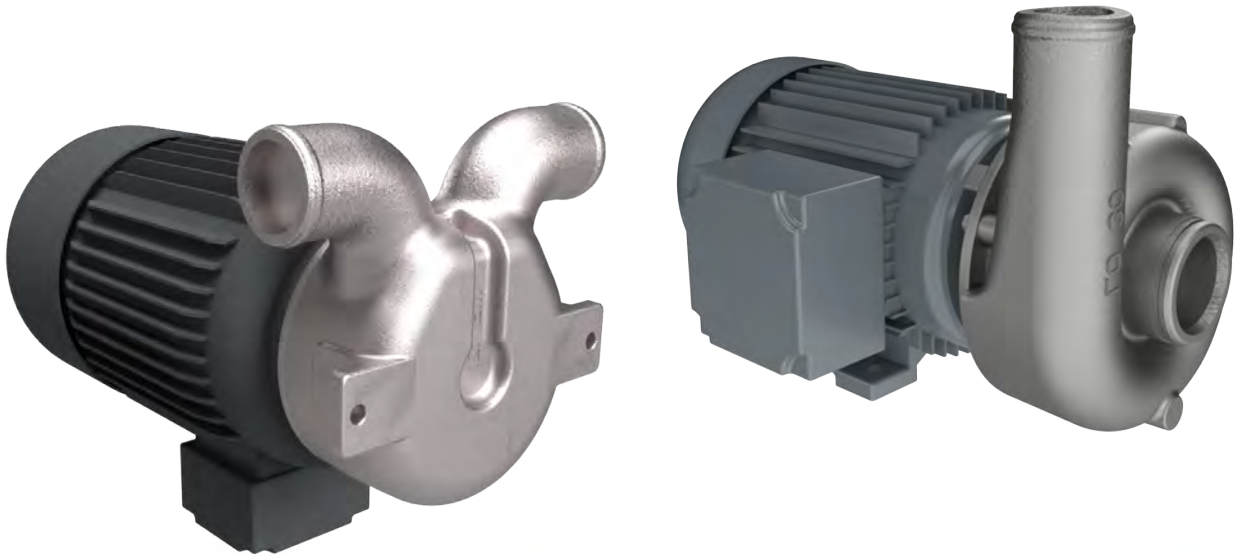

Small and cast stainless steel pumps for clean, slightly polluted, or fuzzy liquids are our compact pumps of the series **LD/S and ME**.

- ⦿ Cast stainless steel as standard for casing and impeller
- ⦿ Non-clog through open or free flow impellers
- ⦿ Connections threaded or hose



Sewage Water Pumps (AWP) can be used in this application as well with a cutting plate or cutting device. Further information to this series can be found in the section "Water and Wastewater".

- ◉ Free of fibre collection
- ◉ Simple cleaning through integrated cleaning piece
- ◉ Wide free passages



You can find the detailed catalog directly at www.strobl-pumpen.de in the "Downloads" section

FOOD & DRUGS

Our **Compact Pumps series ME** can be used in this section. Our high-class pumps machined from bars of stainless steel offer multiple advantages here.

Further information can be found in the section "Cleaning, Washing & Environment".



You can find the detailed catalog directly at www.strobl-pumpen.de in the "Downloads" section



Series EBP offers the possibility of pumps in hygienic execution. These pumps are suitable for clean media and have a structures that allow residue-free drainage, as well as surfaces with minor surface roughness.

- ⦿ Electropolishing of medium touched surfaces
- ⦿ Open impellers and hygienic clamps
- ⦿ Stainless steel as standard execution
- ⦿ FDA approved

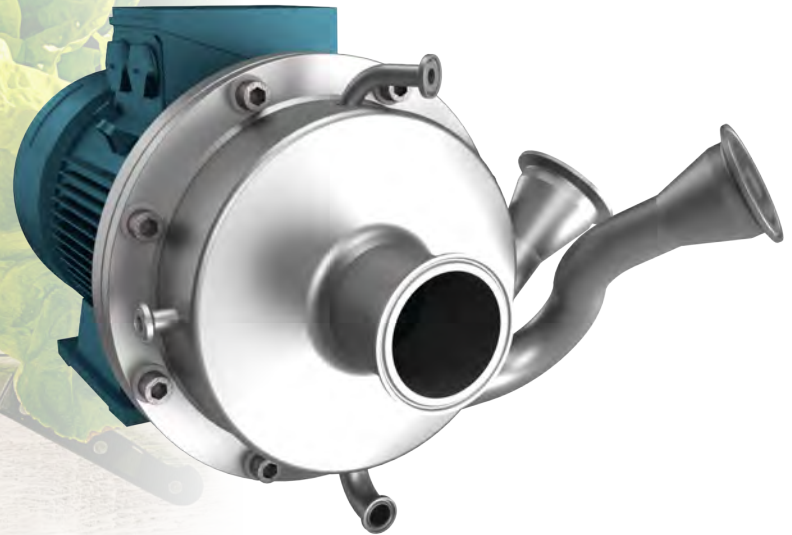

INDUSTRY & PLANT ENGINEERING

All **Chemical Standard Pumps series CNP** correspond the dimensions and performance according to ISO 2858 (similar to ASME B73.1). All sizes can be supplied from a single pump up to complete systems on base plates including motor.

- ⦿ Super high efficiency
- ⦿ Closed multiblade impeller
- ⦿ Durable oil lubricated bearing
- ⦿ Available as submersible execution CNPVS with intermediate pipe and mounting plate

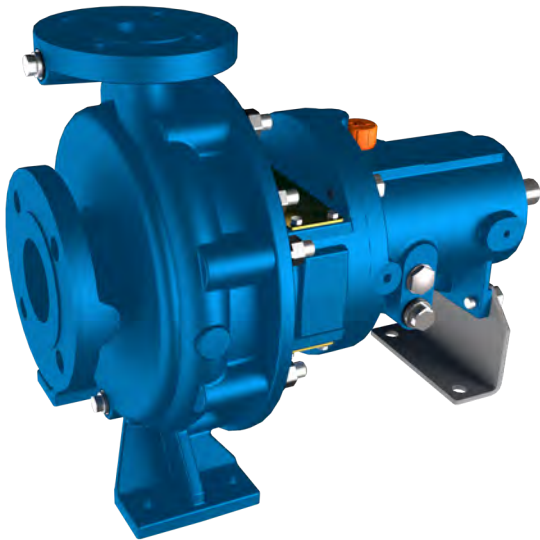



For vertical drainage of tanks and reservoirs our **Sump Pumps series ETP** are ideal.

- ⦿ Guiding bearings from silicon carbide
- ⦿ Medium lubricated sliding bearings
- ⦿ Multistage executions for high heads
- ⦿ Horizontal pressure nozzles above mounting plate



INDUSTRY & PLANT ENGINEERING

In the field of industry & plant engineering our **Sewage Water Pumps series AWP** can be used as well be used. Different sizes and corrosion resistant materials are available. In combination with a large variety of sealing possibilities for high temperatures and pressures this allows for a wide range of applications.

Further information to this series can be found in the section "Water and Wastewater".

- ⦿ High wear resistance
- ⦿ Casing design pressure 40 bar
- ⦿ Sealing with magnet coupling possible



You can find the detailed catalog directly at www.strobl-pumpen.de in the "Downloads" section



The **Compact Pumps in inline version (EBPI)** are ideal for conveying liquids in the building technology with their possibility of direct mounting into the pipe work and their back-pull-out-system. The pumps were constructed in accordance with the ErP-guideline and are supplied with impellers from casted stainless steel as standard.

- ◉ Vibration and temperature resistance
- ◉ Versatile choice of materials and seals
- ◉ Connections for pressure and temperature sensors

CHEMICAL & PETROCHEMICAL INDUSTRY

For applications in the chemical and petrochemical industry our **Chemical Standard Pumps series CNP** are ideal. The dimensions and performance of these pumps are in accordance with ISO 2858 (similar to ASME B73.1). Different executions from standard over ISO 5199 up to API 610-OH1 are possible. The versions can be supplied from single pumps with free shaft end to complete systems with base plate, motor, and all necessary accessories.

- ⦿ Versatile material selection even for highly corrosive mediums
- ⦿ Different sealing varieties (direct mounting, cartridge versions or magnetic drive)
- ⦿ Highest efficiency
- ⦿ Low NPSH version by use of inducer



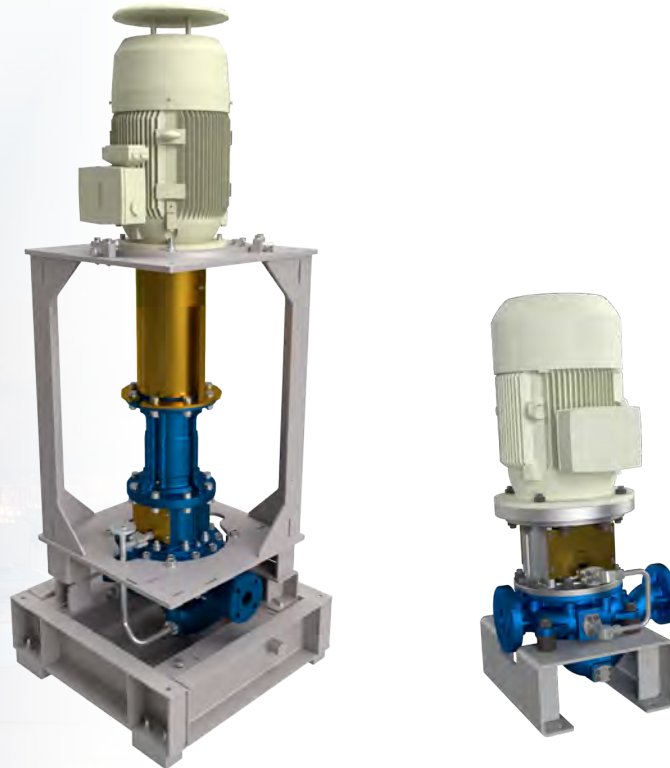

The vertical **Inline Pumps series INP** are characterized by space saving set up possibilities. These pumps are suitable for clean liquids and can be executed completely to API 610-OH3 or OH4.

- ⦿ Nozzle arrangement at same height and rotation in 90° steps
- ⦿ Back-pull-out-system for all executions
- ⦿ Versatile sealing and material combinations
- ⦿ Changeable wear rings on impeller and in casing

CHEMICAL & PETROCHEMICAL INDUSTRY

Pumps series CPP are horizontal **Centreline Process Pumps** with feet at the middle of the axis. An execution to ISO 5199-Family 3 or API 610-OH2 can be supplied. In addition, this series can be produced as sump execution with intermediate pipe and mounting plate (CPPVS).

- ⦿ Possibility of different sealing executions and high corrosion resistant materials
- ⦿ Suction piece with carved optimized flow root faces
- ⦿ System pressures to 40 bar as standard
- ⦿ Changeable wear rings on impeller and in casing

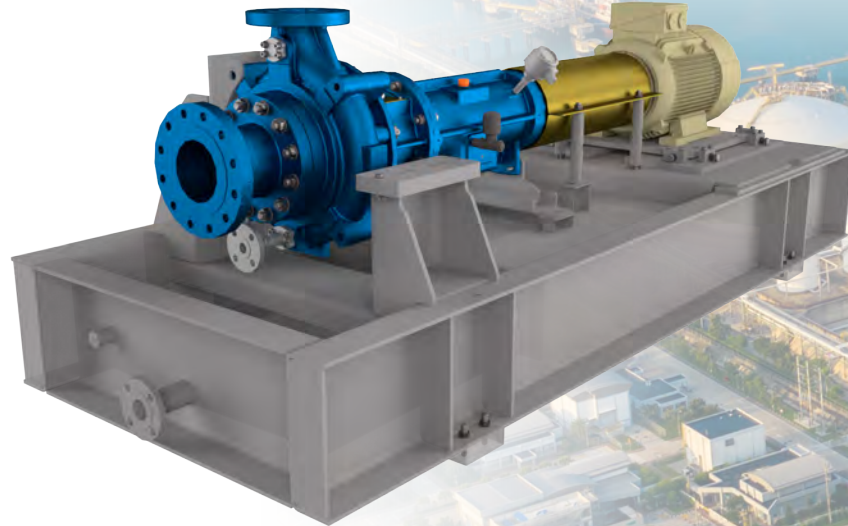

You can find the detailed catalog directly at www.strobl-pumpen.de in the "Downloads" section



Multistage Pumps series SKP are usable horizontally or vertically. This series is ideal for high system pressures of up to 250 bar. Multiple executions to API 610-BB4/BB5 are possible.

- ⦿ Reduction of axial bearing forces through pressure reverse stage
- ⦿ Inner bearings in silicon carbide
- ⦿ Versatile materials and seal options

OFFSHORE

For vertical mounting, our **Sump Pumps series ETP** suit best. This series is in accordance with the construction form API 610-VS1 or ISO 5199-Family 10/12, therefore these pumps can be executed completely to API 610.

- ⦿ Mounting length flexible
- ⦿ Medium lubricated bearings
- ⦿ Guiding bearings in the intermediate pipes from silicon carbide
- ⦿ Horizontal pressure nozzle above mounting plate
- ⦿ Various materials and seal options



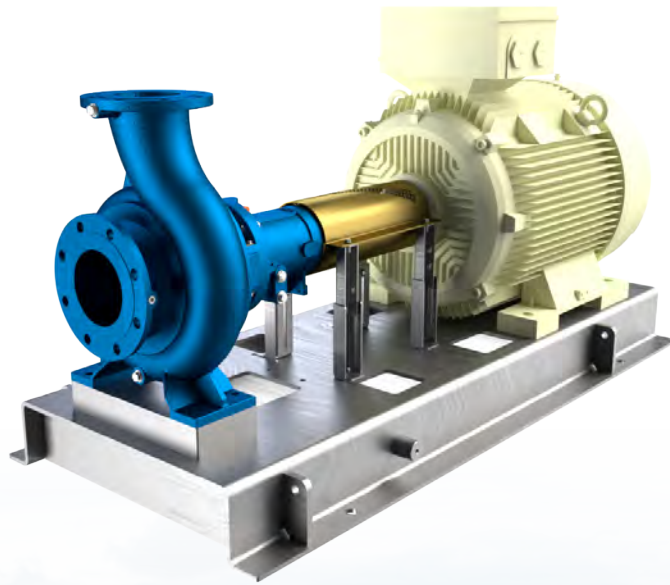

Our **Chemical Standard Pumps series CNP** can be used for these applications as well. Executions to API 610-OH1 or ISO 5199 are possible. Further information to this series can be found in "Chemical & Petrochemical Industry".



API 610

API 685

API 682

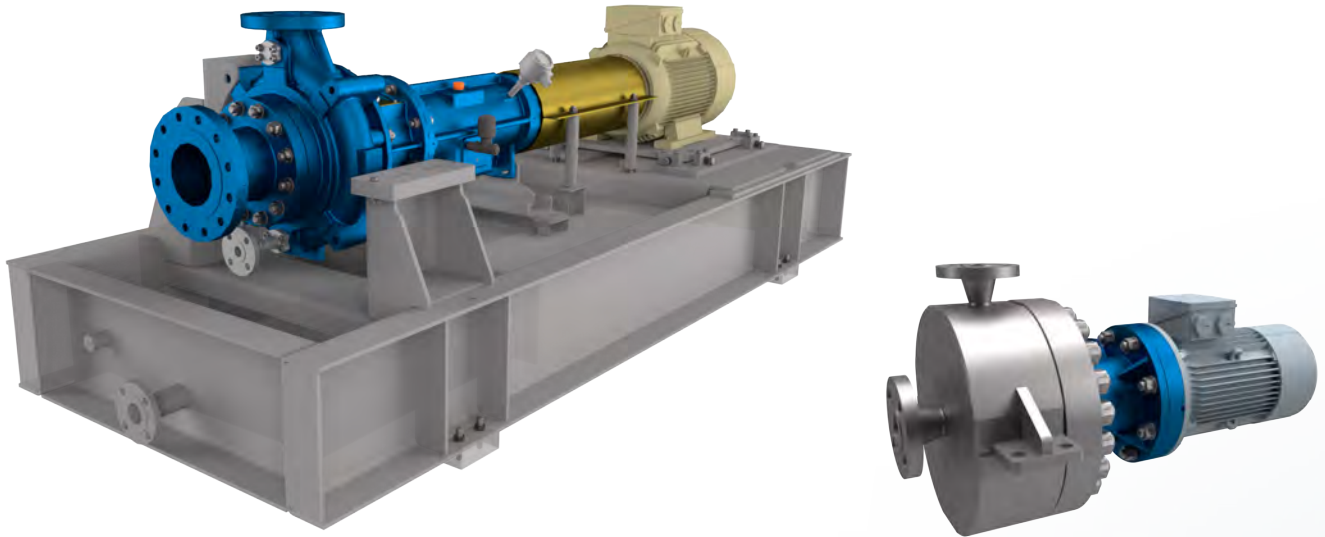

Centreline Process Pumps series CPP characterise themselves through a horizontal construction. In addition, their feet are at the middle of the axis, therefore an execution to API 610-OH2 or ISO 5199-Family 3 is possible. The pumps are designed for 40 bar as standard, higher pressures are possible. Our version CPPVS is a sump execution with intermediate pipe and mounting plate.

- ⦿ Versatile material and seal selection even for highly corrosive mediums
- ⦿ Highest efficiency
- ⦿ Option with inducer for low NPSH
- ⦿ Bearing sealing with contact free labyrinths



Inline Pumps series INP can be used in a variety of ways in this application. The pumps are characterized by space saving set up options and can be completely produced according to API 610-OH3 or OH4.

Information to this series can be found in "Chemical & Petrochemical Industry".



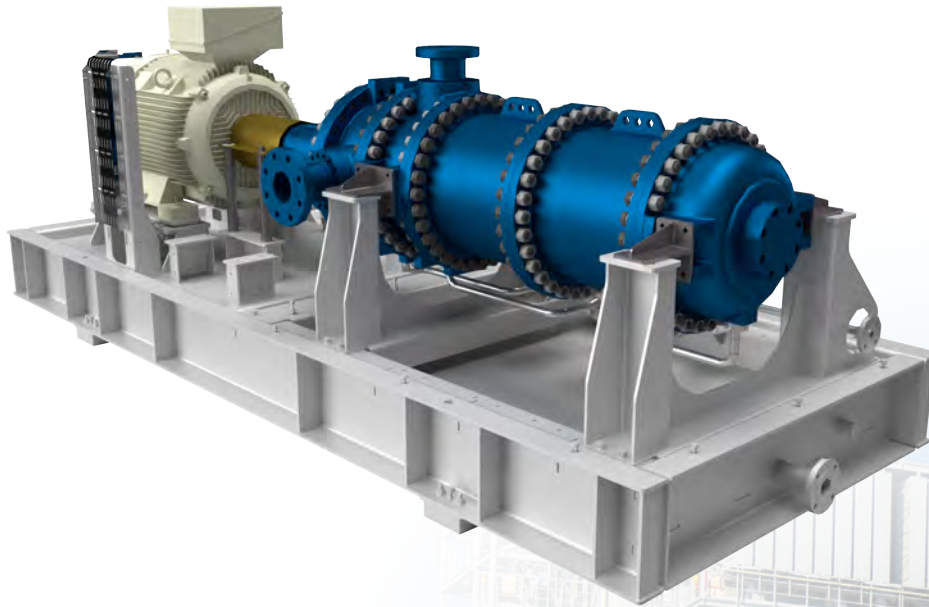

The **multistage centrifugal pumps series SKP** are designed for vertical as well as horizontal applications.. These pumps are ideal for high system pressures of up to 250 bar. Multiple executions to API 610-BB4/BB5 are possible.

Details for this series are in section "Chemical & Petrochemical Industry".



You can find the detailed catalog directly at www.strobl-pumpen.de in the "Downloads" section



For many of the presented pump types, a system for supply to the mechanical seal can be necessary. Seal systems to customer request or to API 682 are possible.

- ⦿ Pressures up to 250 bar
- ⦿ Variety in materials up to high-grade materials such as titanium
- ⦿ Air or water cooling
- ⦿ Instruments analogue or digital

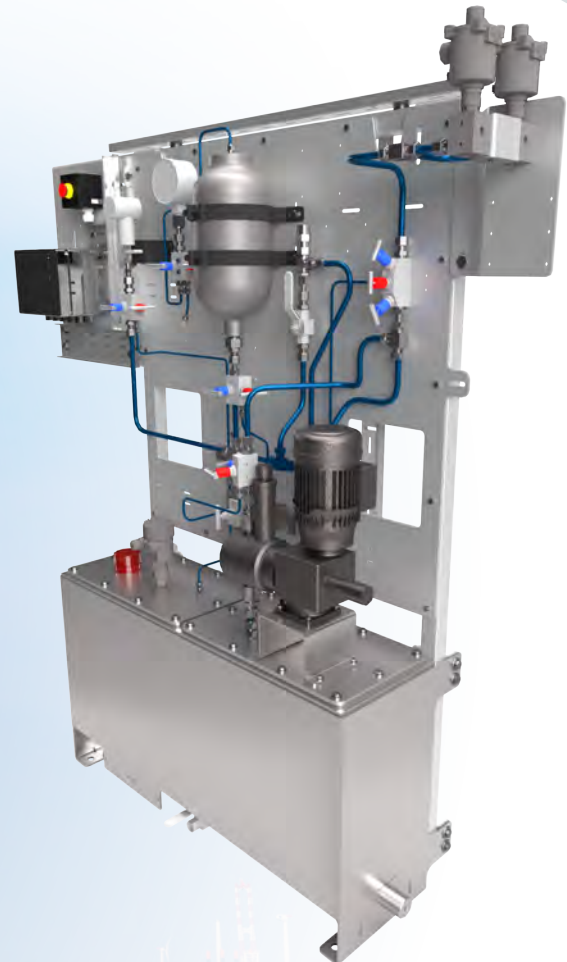

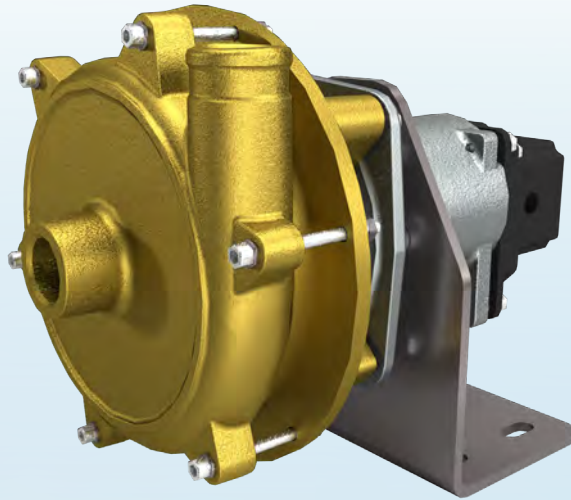

Our **Truck Mixer Pumps series FMP** can be supplied in two sizes for direct mounting to or into vehicles and truck mixers.

- ⦿ Connections threaded or hose
- ⦿ Integration into hydraulic system of vehicles
- ⦿ Various drive options



You can find the detailed catalog directly at www.strobl-pumpen.de in the "Downloads" section





In the application of ship building our pumps series **EBPI as Compact Pumps in inline version** are often used. The direct mounting into the pipe offers a space saving installation.

- ⦿ Shock and shake proof executions
- ⦿ Back-pull-out function
- ⦿ Materials highly corrosion resistant
- ⦿ Drilled connections for pressure and temperature sensors as standard



INDIVIDUAL SOLUTION REQUIRED?

Together we find the solution for your problem in pumping
Contact us!





62.00°

50.00° .01

.03725

4.00°

A

2.00

STROBL PUMPEN

Headquarters

Strobl Pumpen GmbH & Co.KG +49 9174 97708-0
Boschring 3
91161 Hilpoltstein
Germany

info@strobl-pumpen.de

www.strobl-pumpen.de

Connect with us on 



Cooperation and service partner

Bridge Industry Consulting GmbH
Luxemburger Str. 124
50939 Köln
Germany

www.bridge-industry-consulting.de



FM Wäschereitechnik Service AG
Industriestrasse 14
4528 Zuchwil
Switzerland

www.fms.ag



Speck Pumpen Begie NV
Industriestraat 2a
8755 Ruiselede
Belgium

www.speckpumpen.be



Speck Pumpen Nederland B.V.
Stationspoort 10
6902 KG Zevenaar
Netherlands

www.speck.nl



Delta-p
Lensmannlia 4
1386 Asker
Norway

www.delta-p.no



Techno Service S.r.l.
Via Pordenone 21
20821 Meda (MB)
Italy

www.th-service.it



International Technical Construction & Storage Co.
P.O. Box 950279, Ahmad Bani Hameedah Street, Building No. 18
11195 Al-Rabieh, Amman
Jordan
www.itccjo.com



Industrial Systems Group LLP
Makhambet Otemisuly street, bld. 134
Atyrau
Kazakhstan



Kiani pumps and industrial detergent company
Mojtaba Oman
Al Rusail /Al Seeb / Muscat Governorate Oman
+96898877902



IAC-Systems Co. Ltd.
Level 21, Vietcombank Tower, No. 5 Me Linh Square, Sai Gon Ward
71006 Ho Chi Minh
Vietnam
www.iac-systems.com



Teraju Petroleum
Unit 17.2 Level 17 Wisma Sunway
40100 Shah Alam, Selangor
Malaysia
www.terajupetroleum.com



Rotating Technologies Pte Ltd
22 Sin Ming Lane
#06-76 Midview City
Singapore 573969
www.rotatingtechnologies.com.sg





Your Contact



STROBL PUMPEN GMBH & CO. KG - BOSCHRING 3 - 91161 HILPOLTSTEIN
TEL.: +49-9174-97708-0 - WWW.STROBL-PUMPEN.DE - INFO@STROBL-PUMPEN.DE